

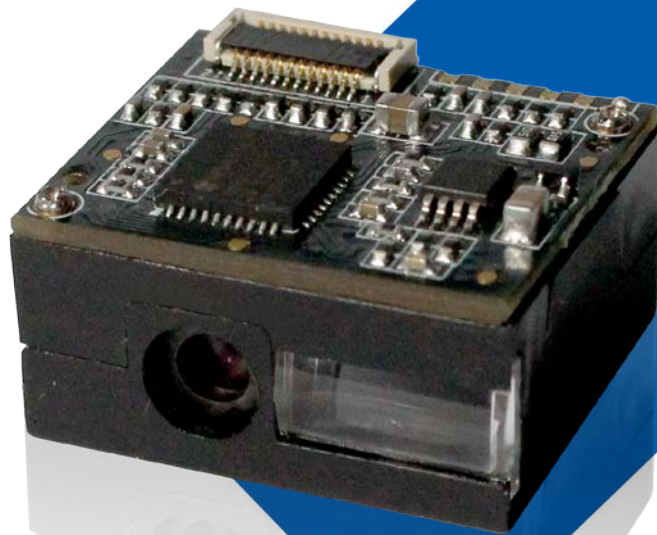

NLS-EM1395-LD
OEM Scan Engine
Integration Guide



Disclaimer

© 2014 Fujian Newland Auto-ID Tech. Co., Ltd. All rights reserved.

Please read through the manual carefully before using the product and operate it according to the manual. It is advised that you should keep this manual for future reference.

Do not disassemble the device or remove the seal label from the device. Otherwise, Fujian Newland Auto-ID Tech. Co., Ltd. does not assume responsibility for the warranty or replacement.

All pictures in this manual are for reference only and actual product may differ. Regarding to the product modification and update, Fujian Newland Auto-ID Tech. Co., Ltd. reserves the right to make changes to any software or product to improve reliability, function, or design at any time without notice. Besides, the information contained herein is subject to change without prior notice.

The products depicted in this manual may include software copyrighted by Fujian Newland Auto-ID Tech. Co., Ltd or a third party. The user, corporation or individual, shall not duplicate, in whole or in part, distribute, modify, decompile, disassemble, decode, reverse engineer, rent, transfer or sublicense such software without prior written consent from the copyright holders.

This manual is copyrighted. No part of this publication may be reproduced, distributed or used in any form without written permission from Newland.

Fujian Newland Auto-ID Tech. Co., Ltd. reserves the right to make final interpretation of the statement above.

Fujian Newland Auto-ID Tech. Co., Ltd.

3F, Building A, No.1, Rujiang Xi Rd., Mawei, Fuzhou, Fujian, P.R. China. 350015.

<http://www.nlscan.com>

Revision History

Version	Description	Date
V1.0.0	Initial release.	May 13, 2014

Table of Contents

Chapter 1 Introduction	1
Overview	1
Illumination	1
Chapter 2 Installation	2
General Requirements	2
ESD	2
Dust and Dirt	2
Ambient Environment	2
Thermal Considerations	2
Installation Orientation	3
Optics	3
Window Placement	3
Window Material and Color	4
Scratch Resistance and Coating	4
Window Size	5
Ambient Light	5
Eye Safety	5
Mounting	6
Front View (unit: mm)	6
Top View (unit: mm)	6
Bottom View (unit: mm)	6
Chapter 3 Electrical Specifications	7
Power Supply	7
Ripple Noise	7
DC Characteristics	8
Operating Voltage	8
Operating Current	8

Chapter 4 Interfaces	9
Host Interface Connector	9
Dimensions of the Host Interface Connector (unit: mm)	10
Flat Flexible Cable (unit: mm).....	11
Communication Interface	11
Trigger	12
Beeper	13
Good Read LED	14
Chapter 5 Development Tools	15
EVK	15

Chapter 1 Introduction

Overview

The EM1395-LD OEM scan engine, armed with the Newland patented **UIMG**[®], a computerized image recognition system, brings about a new era of 1D barcode scan engines.

The EM1395-LD's 1D barcode decoder chip ingeniously blends **UIMG**[®] technology and advanced chip design & manufacturing, which significantly simplifies application design and delivers superior performance and solid reliability with low power consumption.

The EM1395-LD supports EAN-13, EAN-8, UPC-A, UPC-E, ISSN, ISBN, Codabar, Code 128, Code 93, ITF-6, ITF-14, Interleaved 2 of 5, Industrial 2 of 5, Standard 2 of 5, Matrix 2 of 5, GS1 Databar, Code 39, Code 11, MSI-Plessey, Plessey.

Illumination

The EM1395-LD has a red LED (622 nm ~ 628 nm) for supplementary lighting, making it possible to scan barcodes even in complete darkness. The illumination can be programmed On or Off.

The EM1395-LD uses red LED for illumination, so the engine shows better reading performance on barcodes printed in non-red colors. For applications involving red barcodes, it is advised to turn off the engine's illumination and use non-red supplementary lighting instead. The user can conduct some tests to determine the proper wavelengths to be used.

Chapter 2 Installation

General Requirements

ESD

ESD protection has been taken into account when designing the EM1395-LD and the engine is shipped in ESD safe packaging. Always exercise care when handling the engine outside its package. Be sure grounding wrist straps and properly grounded work areas are used.

Dust and Dirt

The EM1395-LD must be sufficiently enclosed to prevent dust particles from gathering on the imager, lens and circuit board. Dust and other external contaminants will eventually degrade the engine's performance.

Ambient Environment

The following environmental requirements should be met to ensure good performance of the EM1395-LD:

Operating Temperature	-20°C ~ 60°C
Operating Temperature	-40°C ~ 85°C
Humidity	5% ~95% (non-condensing)

Thermal Considerations

Electronic components in the EM1395-LD will generate heat during the course of their operation. Operating the EM1395-LD in continuous mode for an extended period may cause temperatures to rise on CIS and decoder chip. Overheating can degrade image quality and affect scanning performance. Given that, the following precautions should be taken into consideration when integrating the EM1395-LD.

- ✧ Reserve sufficient space for good air circulation in the design.
- ✧ Avoid wrapping the EM1395-LD with thermal insulation materials such as rubber.

Installation Orientation

The following figure illustrates a front view of the EM1395-LD after correct installation. From left to right in the figure are lens and illumination (aiming), with decoder board on the top and mounting holes on the bottom.

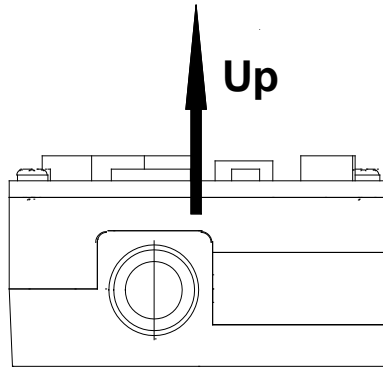

Optics

Window Placement

The window should be positioned properly to let the illumination and aiming beams pass through as much as possible and no reflections back into the engine (reflections can degrade the reading performance).

The window should be mounted close to the front of the engine (parallel). The maximum distance is measured from the front of the engine housing to the furthest surface of the window. In order to reach better reading performance, the distance from the front of the engine housing to the furthest surface of the window should not exceed 3mm and the distance from the front of the engine housing to the nearest surface of the window should not exceed 2mm.

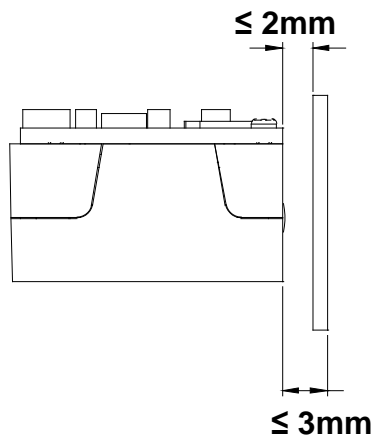

If the window is required to be in a tilted position, the above distance requirements should be met and tilt angle should ensure no reflections back into the lens.

Window Material and Color

Wavelength of illumination beam and CIS's responsiveness (mainly to wavelengths of red light) should be taken into consideration when choosing window material and color, to achieve the possible highest spectral transmission, lowest haze level and homogeneous refractive index. It is suggested to use PMMA or optical glass with spectral transmittance over 90% and haze less than 1%. Whether to use an anti-reflection coating or not depends on the material and application needs.

Scratch Resistance and Coating

Scratch on the window can greatly reduce engine performance. It is recommended to use abrasion resistant window material or coating.

Window Size

The window must not block the field of view and should be sized to accommodate the illumination envelope shown below.

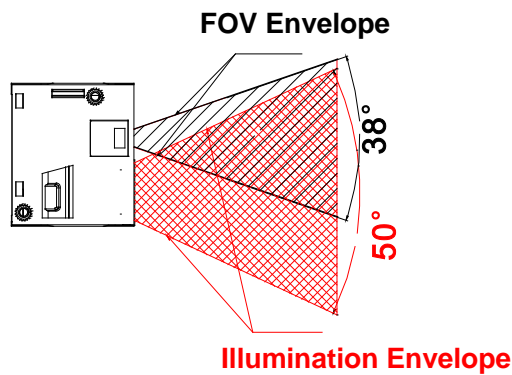
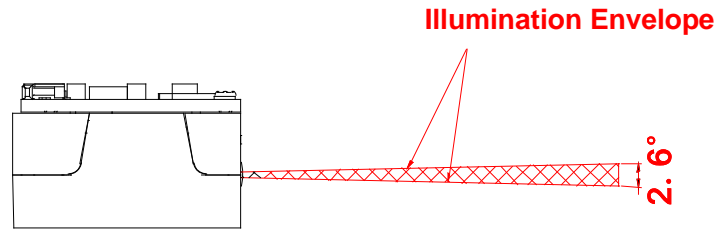

Ambient Light

The EM1395-LD shows better performance with ambient light and it is well able to handle the flicker in fluorescent lights using 50-60Hz AC power. However, high-frequency pulsed light can result in performance degradation.

Eye Safety

The EM1395-LD has no lasers. It uses a red LED to create aiming and illumination beams. The LED is bright, but testing has been done to demonstrate that the engine is safe for its intended application under normal usage conditions. However, the user should avoid looking into the beam.

Mounting

The illustrations below show the mechanical mounting dimensions for the EM1395-LD. The structural design should leave some space between components and reserve enough room for the flat flexible cable.

Front View (unit: mm)

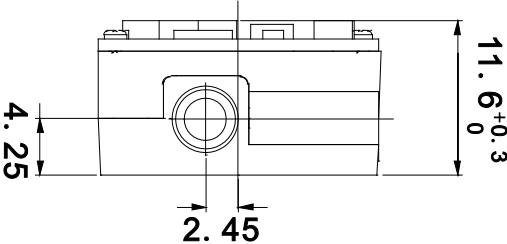

Top View (unit: mm)

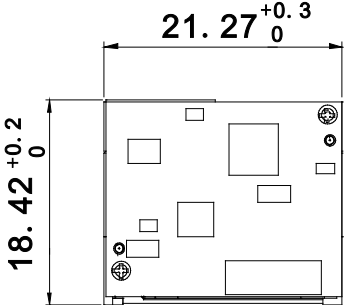

Bottom View (unit: mm)

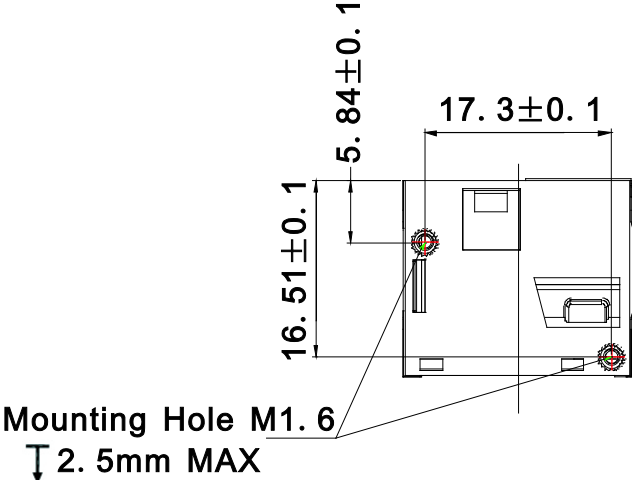

Chapter 3 Electrical Specifications

Power Supply

Do not power up the EM1395-LD until it is properly connected. Be sure the power is cut off before connecting a flexible cable to or disconnecting a flexible cable from the host interface connector. Hot-plugging could damage the engine.

Unstable power supply or sharp voltage drops or unreasonably short interval between power-ons may lead to unstable performance of the engine. Do not resupply the power immediately after cutting it off. The minimum interval must exceed 500ms.

The EM1395-LD itself does not provide a power switch. Users can switch the engine off by cutting off the power.

The EM1395-LD's start-up time is less than 200ms.

Ripple Noise

Image sensor and decoder chip are directly fed by the input power of EM1395-LD. To ensure the stable performance, a power supply with low ripple noise is needed.

Acceptable ripple range (peak-to-peak) : $\leq 100\text{mV}$ ($\leq 50\text{mV}$ recommended).

DC Characteristics

Operating Voltage

Ta=25°C

Parameter	Description	Minimum	Typical	Maximum	Unit
V _{DD}	Voltage Drain Drain	3.0	3.3	3.6	V
V _{IH}	High Level Input Voltage	0.7*V _{DD}	-	-	V
V _{IL}	Low Level Input Voltage	-	-	0.2*V _{DD}	V
V _{OH}	High Level Output Voltage	0.9*V _{DD}	-	-	V
V _{OL}	Low Level Output Voltage	-	-	0.1*V _{DD}	V

Operating Current

Ta=25°C, V_{DD}=3.3V

Operating Current	Standby Current	Unit
65	9	mA

Chapter 4 Interfaces

Host Interface Connector

The following table lists the pin functions of the 12-pin host interface connector on the EM1395-LD.

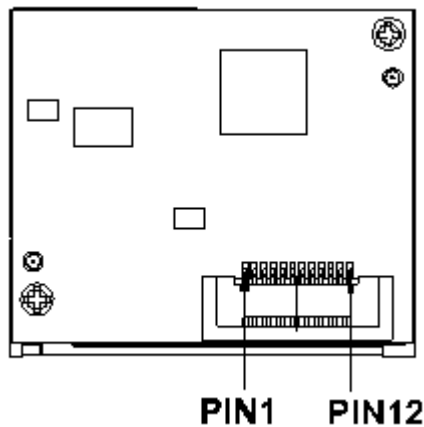

PIN#	Signal Name	I/O	Function
1	NC	-	Not connected.
2	VDD	-	3.3V power supply.
3	GND	-	Power-supply ground.
4	RX	I	TTL level 232 receive data.
5	TX	O	TTL level 232 transmit data.
6	USB_D-	I/O	USB_D- differential data signal.
7	USB_D+	I/O	USB_D+ differential data signal.
8	PWRDWN	O	Low Power State signal output: Active high indicates that the engine is in low power state.
9	Buzz	O	Beeper output. For the information of beeper driver circuit, see the Beeper section in this chapter.
10	LED	O	Good Read LED output. For the information of LED driver circuit, see the Good Read LED section.
11	Wake	I	Same as the nTrig pin (PIN 12).
12	nTrig	I	Trigger signal input: Driving this pin low for at least 10ms causes the engine to start a scan and decode session.

Dimensions of the Host Interface Connector (unit: mm)

The engine uses a 12-pin ZIF socket (bottom contact, model: 10051922-1210ELF/ 10051922-1210EHLF) manufactured by FCI. The socket can be connected to a host device with a flat flexible cable.

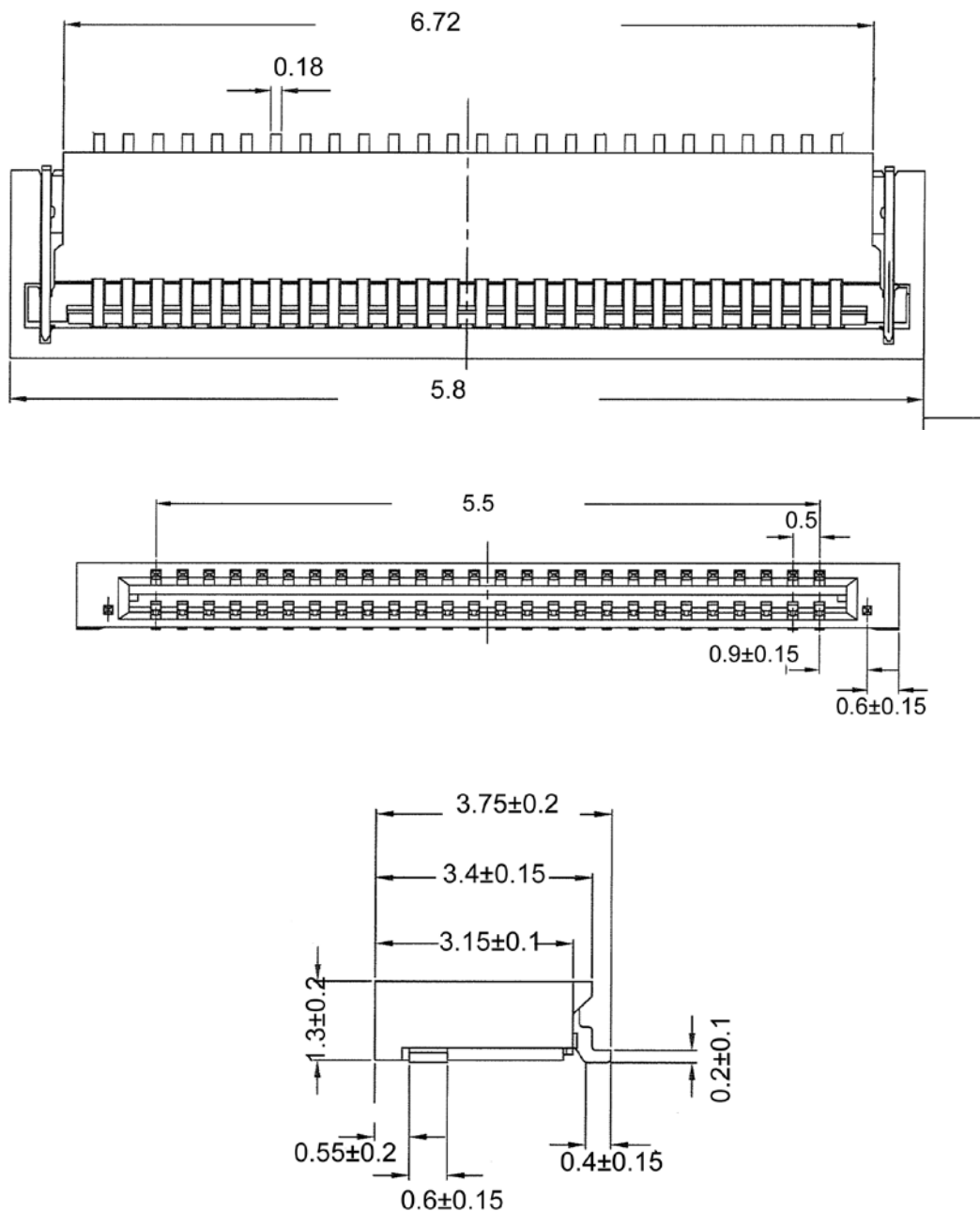

Flat Flexible Cable (unit: mm)

A 12-pin flat flexible cable can be used to connect the EM1395-LD to a host device. The cable design must be consistent with the specifications shown below. Use reinforcement material for the connectors on the cable and reduce cable impedance for reliable connection and stable performance.

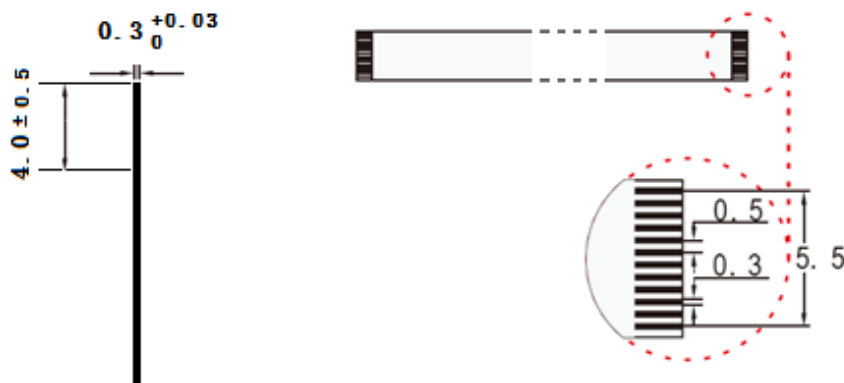

Communication Interface

The EM1395-LD can communicate with the host device through one of the following interfaces:

- ✧ TTL-232: This interface, in most cases, does not require any hardware modifications to existing platforms. However, for those requiring RS-232, a TTL-232 to RS-232 conversion circuit is needed.
- ✧ USB HID-KBW: Based on USB connection, the engine's transmission is simulated as USB keyboard input. It works on a Plug and Play basis and no driver is required.
- ✧ USB COM Port Emulation: The USB port on the host device is emulated as a serial port with the same data transmission and configuration as a real serial port. A driver is required.
- ✧ USB DataPipe: This protocol is defined by Newland. A driver is required when using this protocol to communicate with scanner.
- ✧ HID-POS: HID-POS does not require a custom driver. However, an HID interface on Windows 98 does. All HID interfaces employ standard driver provided by the operating system.

The EM1395-LD's serial port supports baud rates from 1200bps to 115200bps; it does not support hardware or software flow control. Its default settings are 9600bps, 8 data bits, no parity check and 1 stop

bit.

Trigger

Driving the nTrig pin (PIN 12) on the host interface connector low for over 10ms causes the EM1395-LD to start a scan and decode session. If barcode is decoded, the EM1395-LD waits for the voltage at the nTrig pin to turn high (or the trigger to be released) after sending the data to the Host. If the trigger is released during a scan attempt, the EM1395-LD immediately stops decoding.

Next decode session does not happen until the EM1395-LD receives active trigger signal (driving the nTrig pin low) again.

As a decode session involves image capture, barcode decoding and other steps, it is suggested that the minimum interval between two triggers should exceed 50ms.

The following trigger circuit is provided for reference.

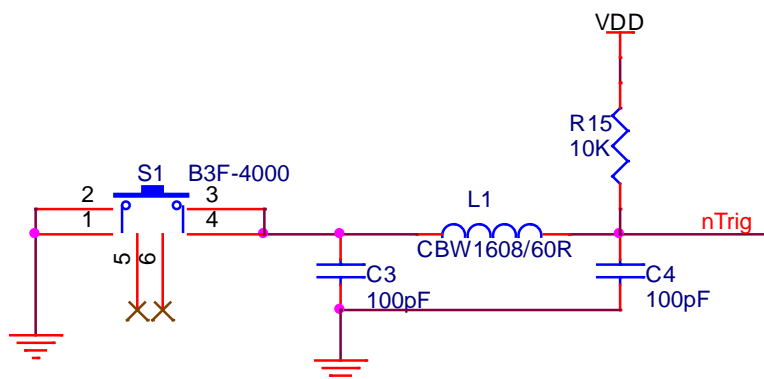

Beeper

The EM1395-LD provides a pin (Buzz, PIN 9) on the host interface connector that provides a PWM output to an external driver circuit for generating audible feedback to the user to indicate statuses like power up or good decode. The PWM output is not strong enough to drive a beeper, thus a beeper driver circuit is needed.

The following beeper driver circuit is provided for reference.

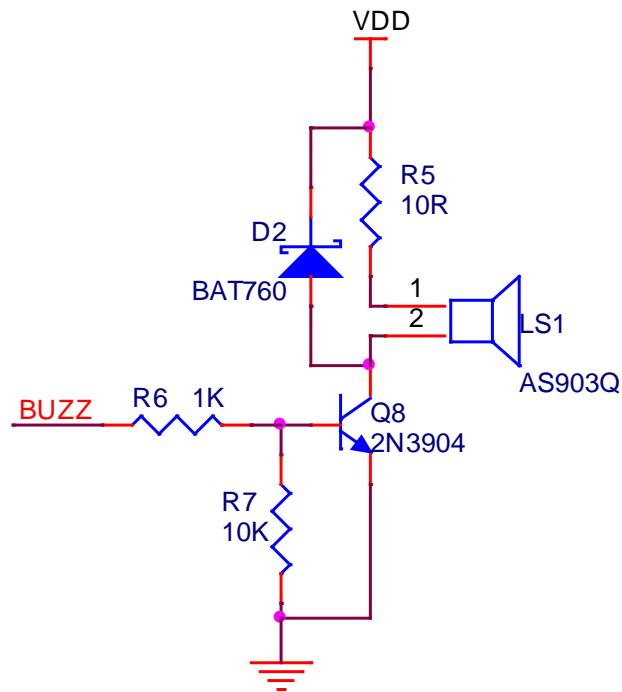

Good Read LED

The EM1395-LD provides a pin (LED, PIN 10) on the host interface connector that can be used by an external driver circuit to drive an LED to indicate a Good Read status. When a good read occurs, the LED pin produces a high level output for about 300ms, then the signal is back to a low level. This Good Read LED output is not strong enough to drive an LED, so an LED driver circuit is needed.

The following Good Read LED driver circuit is provided for reference.

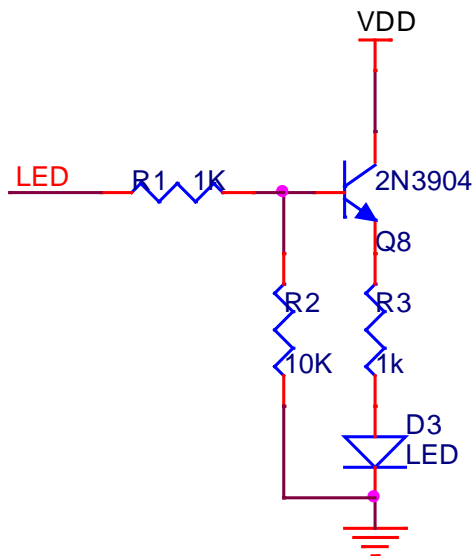

Chapter 5 Development Tools

EVK

The EVK is provided to help users to test and evaluate the EM1395-LD, which contains beeper & beeper driver circuit, LED & LED driver circuit, trigger & reset buttons, TTL-232 to RS-232 converter & TTL-232 to USB converter, RS-232 & USB interfaces, etc. The EM1395-LD can be connected to the EVK via a 12-pin flat flexible cable. Either USB or RS-232 connection can be used when connecting the EVK to a host device.



Headquarters / 总部

福建新大陆自动识别技术有限公司

地址: 福建省福州市马尾区儒江西路 1 号新大陆科技园

邮编: 350015

电话: +86 - (0) 591-83979222

传真: +86 - (0) 591-83979208

E-mail: marketing@nlscan.com

WEB: www.nlscan.com

Newland Europe BV/ 欧洲新大陆有限公司

Rolweg 25, 4104 AV Culemborg, The Netherlands

TEL: +31 (0) 345 87 00 33

FAX: +31 (0) 345 87 00 39

Email: sales@newland-id.com

WEB: www.newland-id.com

Tech Support: tech-support@newland-id.com

Newland North America Inc. / 北美新大陆有限公司

Address: 46559 Fremont Blvd., Fremont, CA 94538, USA

TEL: 510 490 3888

Fax: 510 490 3887

Email: info@newlandna.com

WEB: www.newlandna.com

Newland Taiwan Inc. / 台湾新大陆资讯科技股份有限公司

7F-6, No. 268, Liancheng Rd., Jhonghe Dist. 235, New Taipei City, Taiwan

新北市 235 中和區連城路 268 號 7 樓之 6 (遠東世紀廣場 J 棟)

TEL: +886 2 7731 5388

FAX: +886 2 7731 5389

Email: sales.tw@newland-id.com

WEB: www.newland-id.com.tw