

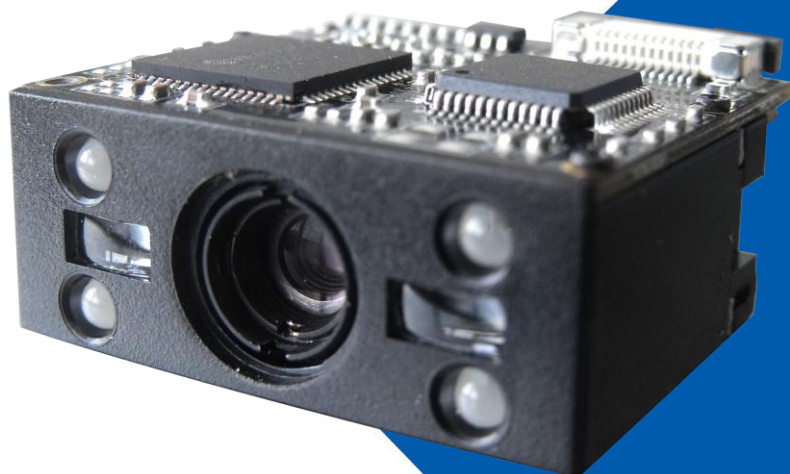

NLS-EM3070 Series

Embedded 2D Barcode Scan Engine

Integration Guide



Disclaimer

© 2013 Fujian Newland Auto-ID Tech. Co., Ltd. All rights reserved.

Please read through the manual carefully before using the product and operate it according to the manual. It is advised that you should keep this manual for future reference.

Do not disassemble the device or remove the seal label from the device. Otherwise, Fujian Newland Auto-ID Tech. Co., Ltd. does not assume responsibility for the warranty or replacement.

All pictures in this manual are for reference only and actual product may differ. Regarding to the product modification and update, Fujian Newland Auto-ID Tech. Co., Ltd. reserves the right to make changes to any software or product to improve reliability, function, or design at any time without notice. Besides, the information contained herein is subject to change without prior notice.

The products depicted in this manual may include software copyrighted by Fujian Newland Auto-ID Tech. Co., Ltd or a third party. The user, corporation or individual, shall not duplicate, in whole or in part, distribute, modify, decompile, disassemble, decode, reverse engineer, rent, transfer or sublicense such software without prior written consent from the copyright holders.

This manual is copyrighted. No part of this publication may be reproduced or used in any form without written permission from Newland.

Fujian Newland Auto-ID Tech. Co., Ltd. reserves the right to make final interpretation of the statement above.

Fujian Newland Auto-ID Tech. Co., Ltd.

3F, Building A, No.1, Rujiang Xi Rd., Mawei, Fuzhou, Fujian, P.R. China. 350015.

<http://www.nlscan.com>

Revision History

Version	Description	Date
V1.0.0	Initial release.	January 17, 2013

Table of Contents

Chapter 1 Introduction	1
Overview	1
Aimer	1
Illumination	1
Chapter 2 Installation	2
General Requirements	2
ESD	2
Dust and Dirt	2
Ambient Environment	2
Thermal Considerations	2
Installation Orientation	3
Optics	3
Window Placement	3
Window Material and Color	4
Scratch Resistance and Coating	4
Window Size	4
Ambient Light	5
Eye Safety	5
Mounting	5
Front View (unit: mm)	6
Left View (unit: mm)	6
Bottom View (unit: mm)	6
Chapter 3 Electrical Specifications	7
Power Supply	7
Ripple Noise	7
DC Characteristics	7
Operating Voltage	7
Current	8
Chapter 4 Interfaces	9

Host Interface Connector.....	10
Dimensions of the Host Interface Connector.....	11
Flat Flexible Cable	12
Cable Connection	12
Communication Interfaces.....	13
Control Interfaces.....	13
Reset	13
Trigger.....	13
Beeper	14
Decode LED.....	15
Chapter 5 Development Tools	16
EVK.....	16
QuickSet / uExpress.....	16

Chapter 1 Introduction

Overview

NLS-EM3070 series embedded 2D barcode scan engines, armed with the Newland patented **UIMG**[®], a computerized image recognition system, bring about a new era of 2D barcode scan engines.

The EM3070's decoder chip ingeniously blends **UIMG**[®] technology and advanced chip design & manufacturing, which significantly simplifies application design and delivers superior performance and solid reliability with low power consumption.

The EM3070 supports all mainstream 1D and standard 2D barcode symbologies (e.g., PDF417, QR Code M1/M2/Micro and Data Matrix) as well as GS1-DataBarTM(RSS) (Limited/Stacked/Expanded versions).

Aimer

The EM3070 has a view finder that projects an aiming beam to help the user to position the target barcode within the engine's field of view to increase scan efficiency. The aimer can be programmed On or Off. It is advisable to turn it on when scanning barcodes.

Illumination

The EM3070 has several red LEDs (wavelength: 625±10 nm) for supplementary lighting, making it possible to scan barcodes even in complete darkness. The illumination can be programmed On or Off.

The use of red light as illumination and the engine's lens imaging system designed to work better with red light result in that the engine shows better reading performance on barcodes printed in non-red colors. For applications involving red barcodes, it is advised to turn off the engine's illumination and use non-red supplementary lighting instead. The user can conduct some tests to determine the proper wavelengths to be used.

Chapter 2 Installation

General Requirements

ESD

ESD protection has been taken into account when designing the EM3070 and the engine is shipped in ESD safe packaging. Always exercise care when handling the engine outside its package. Be sure grounding wrist straps and properly grounded work areas are used.

Dust and Dirt

The EM3070 must be sufficiently enclosed to prevent dust particles from gathering on the imager and lens. Dust and other external contaminants will eventually degrade the engine's performance.

Ambient Environment

The following environmental requirements should be met to ensure good performance of the EM3070:

Working Temperature	-20°C to 55°C
Storage Temperature	-40°C to 80°C
Humidity	5% to 95% (non-condensing)

Thermal Considerations

Electronic components in the EM3070 generate heat during the course of their operation. Operating the EM3070 in continuous mode for an extended period may result in an increase in temperature by 20°C inside the engine. The following precautions should be taken when integrating the EM3070:

- ✧ Reserve sufficient space for good air circulation during design.
- ✧ Avoid wrapping the EM3070 with thermal insulation materials such as rubber.

Installation Orientation

The following figure illustrates a front view of the EM3070 after installation.

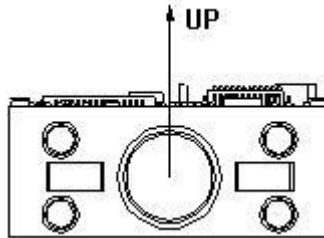

Optics

Window Placement

The window should be positioned properly to let the illumination and aiming beams pass through as much as possible and no reflections back into the engine (reflections can degrade the reading performance).

The window should be mounted close to the front of the engine (parallel). The maximum distance is measured from the front of the engine housing to the farthest surface of the window. Avoid unwanted reflections and use thin material for window so as to reach better reading performance. As shown in the figure below, the distance from the front of the engine housing to the furthest surface of the window should not exceed 3mm and the distance from the front of the engine housing to the nearest surface of the window should not exceed 2mm.

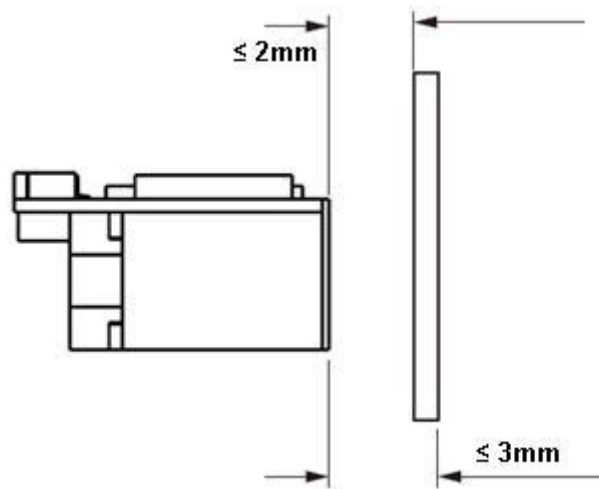

If the window is required to be in a tilted position, the above distance requirements should be met and tilt angle should ensure no reflections back into the lens.

Window Material and Color

Wavelengths of illumination and aiming beams should be taken into consideration when choosing window material and color, to achieve the possible highest spectral transmission, lowest haze level and homogeneous refractive index. It is suggested to use PMMA or optical glass with spectral transmittance over 90% and haze less than 1%. Whether to use an anti-reflection coating or not depends on the material and application needs.

Scratch Resistance and Coating

Scratch on the window can greatly reduce the performance of the EM3070. It is suggested to use abrasion resistant window material or coating.

Window Size

The window must not block the field of view and should be sized to accommodate the aiming and illumination envelopes shown below.

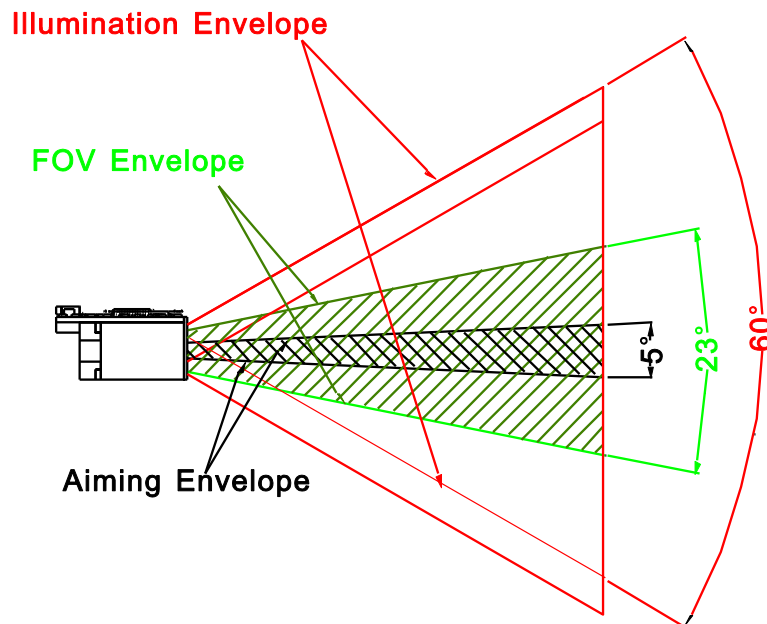

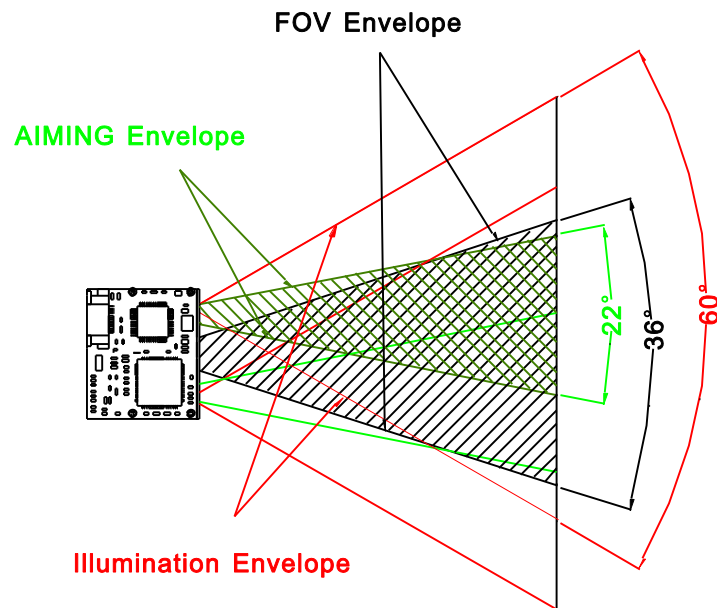

Ambient Light

The EM3070 shows better performance with ambient light. However, high-frequency pulsed light can result in performance degradation.

Eye Safety

The EM3070 has LEDs that create the aiming and illumination beams. These LEDs are bright, but testing has been done to demonstrate that the engine is safe for its intended application under normal usage conditions. However, the user should avoid looking into the beam.

Mounting

The illustrations below show the mechanical mounting dimensions for the EM3070. The structural design should leave some space between components and provide sufficient space for flat flexible cable.

Elements listed in previous sections should also be taken into consideration when integrating the EM3070.

Front View (unit: mm)

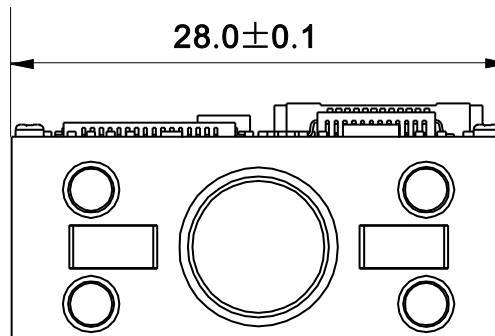

Left View (unit: mm)

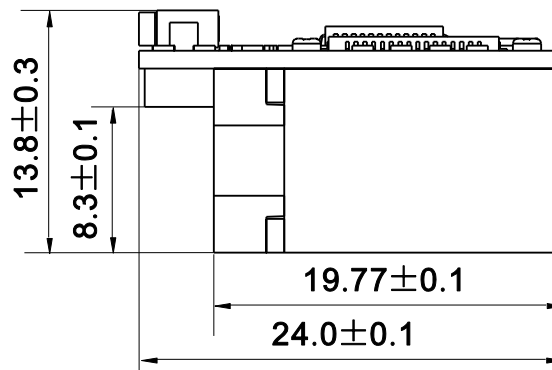

Bottom View (unit: mm)

The bottom view shows the mounting screw specification (M2, machine screw with an internal diameter of 2mm). Note that the part of mounting screws into the engine can not exceed 3mm.

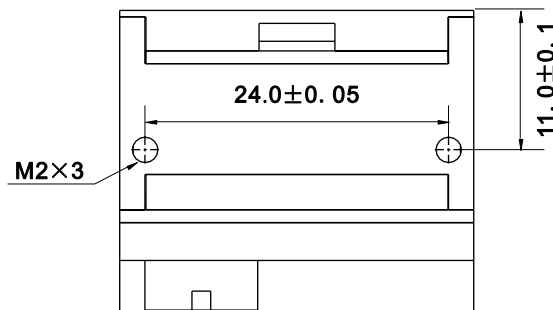

Chapter 3 Electrical Specifications

Power Supply

Do not power up the EM3070 until it is properly connected. Be sure the power is cut off before connecting a flexible cable to or disconnecting a flexible cable from the host interface connector. This could damage the engine.

Unstable power supply or sharp voltage drops or unreasonably short interval between power-ons may lead to unstable performance of the engine. Do not resupply the power immediately after cutting it off. The minimum interval must exceed 2 seconds.

Ripple Noise

To ensure the image quality, a power supply with low ripple noise is needed.

Acceptable ripple range (peak-to-peak) : $\leq 50\text{mV}$ ($\leq 30\text{mV}$ recommended).

DC Characteristics

Operating Voltage

$T_a=25^\circ\text{C}$

Parameter	Minimum	Typical	Maximum	Unit
V_{CC}	3.1	3.3	3.6	V
V_{IH}	$V_{CC}-0.5$	-	-	V
V_{IL}	-	-	0.5	V
V_{OH}	$V_{CC}-0.3$	-	-	V
V_{OL}	-	-	0.3	V

Current

T_a=25°C, VCC=3.3V

Parameter	Average	Maximum	Unit
I _{OP}	180	-	mA
I _{Standby}	6	-	mA
I _{Low power}	2	-	uA

Chapter 4 Interfaces

The following table lists the pin functions of the 12-pin host interface connector. Refer to the “**Cable Connection**” section in this chapter for the location of Pin 1.

PIN#	Signal Name	I/O	Function
1	VCC	-	Power supply
2	VCC	-	Power supply
3	GND	-	Ground
4	RX	Input	TTL-232 receiving
5	TX	Output	TTL-232 transmission
6	D-	Input/Output	USB D- differential data signal
7	D+	Input/Output	USB D+ differential data signal
8	GND	-	Ground
9	BUZ	Output	Beeper output. For the information of beeper driver circuit, see the “ Control Interfaces ” section.
10	LED	Output	Decode LED output. For the information of LED driver circuit, see the “ Control Interfaces ” section.
11	RESET	Input	Reset signal input: Driving this pin low for at least 100 μ s causes the EM3070 to reset.
12	TRIG	Input	Trigger signal input: Driving this pin low for at least 10ms causes the EM3070 to start a scan and decode session.

Host Interface Connector

The EM3070's host interface connector is a 12-pin ZIF socket which can be used to connect a host device (e.g., EM3070 software development board EVK) with a flat flexible cable. The following figures show the position and dimensions of the socket. (unit: mm)

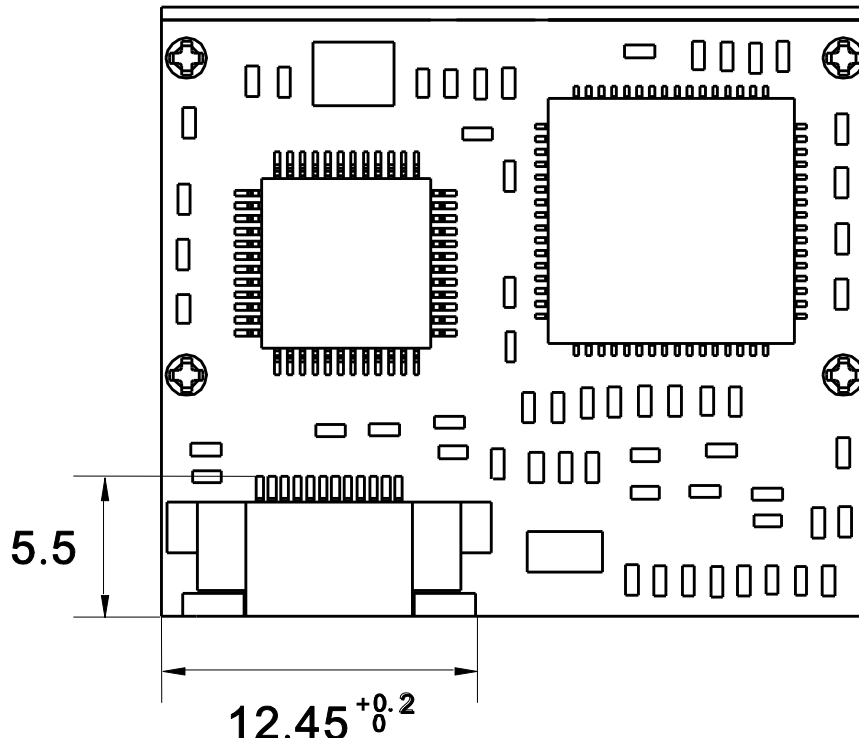

Dimensions of the Host Interface Connector

unit: mm

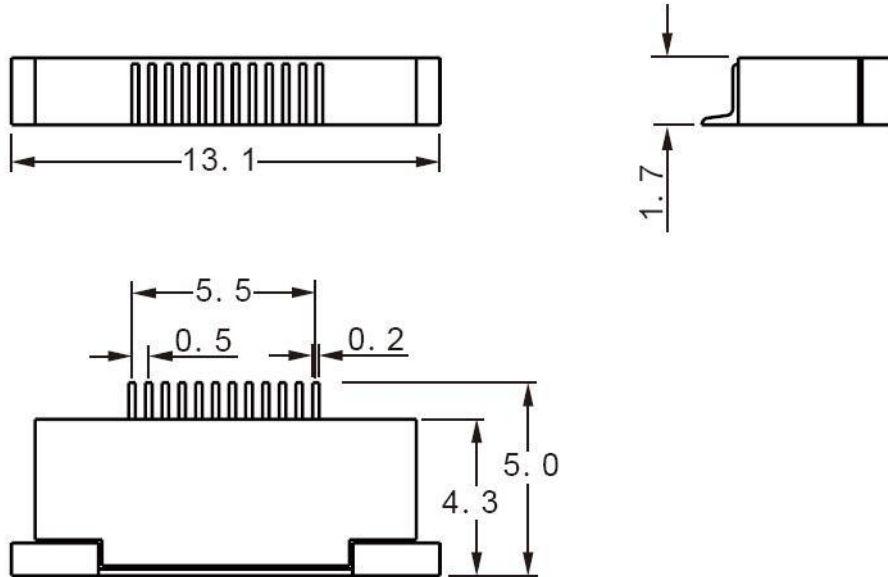

Flat Flexible Cable

A 12-pin flat flexible cable can be used to connect the EM3070 to OEM equipment or to the EM3070 EVK. The cable design must be consistent with the following specifications shown below. Use reinforcement material for the connectors on the cable and reduce cable impedance for reliable connection and stable performance.

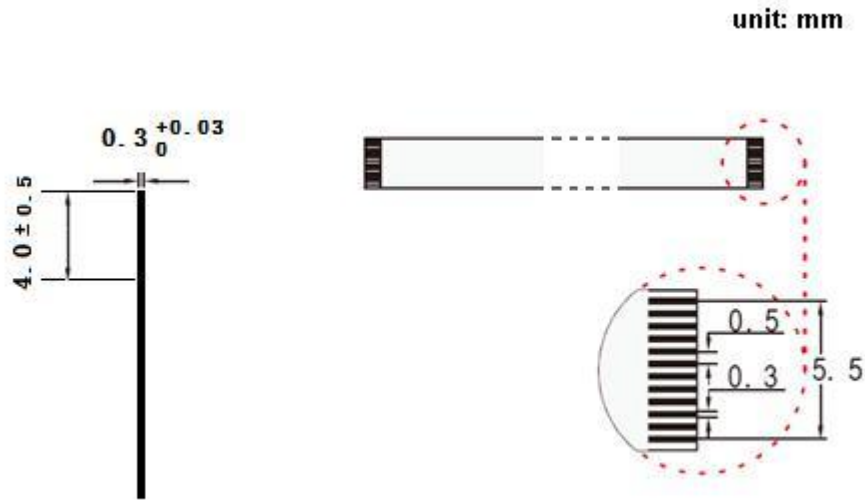

Cable Connection

Be sure the power is cut off before connecting a flexible cable to the host interface connector on the EM3070. Hot plugging could damage the engine or the host device.

Connect the EM3070 to a host device via a 12-pin flexible cable as shown in the following figure.

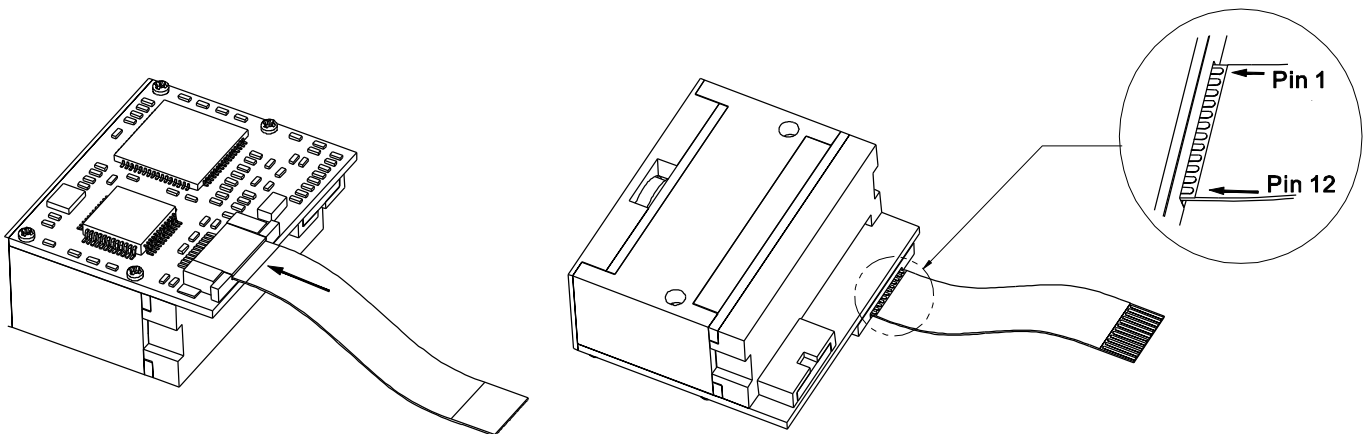

Communication Interfaces

The EM3070 can communicate with the host device through either TTL-232 serial port or USB port. It provides 3 communication modes:

- ✧ TTL-232: This interface is applicable to most system architectures. For those requiring RS-232, a TTL-232 to RS-232 conversion circuit is needed.
- ✧ USB HID-KBW: Based on USB connection, the engine's transmission is simulated as USB keyboard input. It works on a Plug and Play basis and no driver is required.
- ✧ USB COM Port Emulation: The USB port on the host device is emulated as a serial port with the same data transmission and configuration as a real serial port. A driver is required.

The EM3070's serial port supports baud rates from 1200bps to 115200bps; it does not support hardware flow control.

Control Interfaces

Reset

Driving the RESET pin (PIN 11) on the host interface connector low for at least 100 μ s (but cannot exceed 500 μ s) and then back to high or idle high causes the EM3070 to reset.

The minimum interval between reset operations must exceed 2 seconds.

Trigger

Driving the TRIG pin (PIN 12) on the host interface connector low for a specified time period causes the EM3070 to start a scan and decode session. The time period varies from one scan mode to another. Anti-shake mechanism is used in level trigger mode. Trigger is activated in this mode if the signal from the TRIG pin remains low for at least 10ms.

For those scan modes with a timeout mechanism, the engine can automatically deactivate the trigger when a timeout occurs. After one trigger, the engine gets ready for next trigger only if the signal from the TRIG pin remains high for at least 10ms.

Beeper

The EM3070 provides a pin (BUZ, PIN 9) on the host interface connector that provides a PWM output to an external driver circuit for generating audible feedback to the user to indicate statuses like power up, good decode or operation mistake. The PWM output is not strong enough to drive a beeper, so a beeper driver circuit is needed.

The following beeper driver circuit is provided for reference.

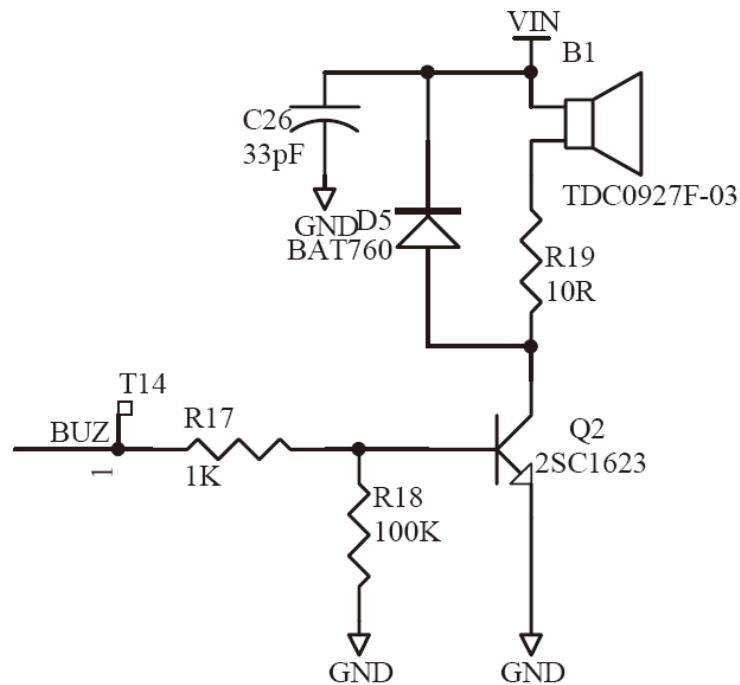

Decode LED

The EM3070 provides a pin (LED, PIN 10) on the host interface connector that can be used by an external driver circuit to drive an LED to indicate a Good Decode status. When a good decode occurs, the signal from the LED pin turns from a low level into alternation of high and low levels and then back into a low level. This Decode LED output is not strong enough to drive an LED, so an LED driver circuit is needed.

The following decode LED driver circuit is provided for reference.

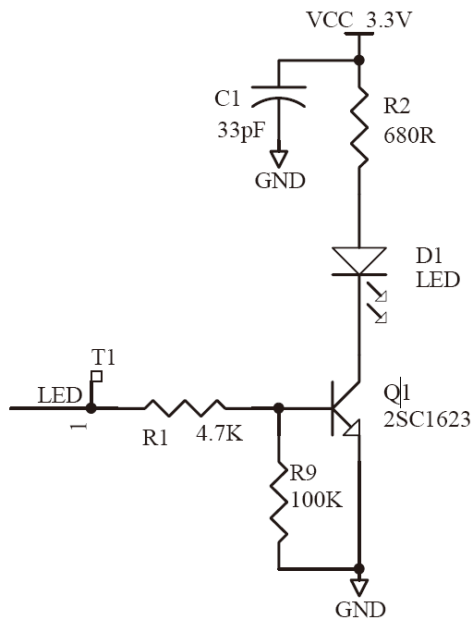

Chapter 5 Development Tools

The EM3070's development tools include both software and hardware and can be utilized for engine performance evaluation, application development and engine configuration.

EVK

The EVK is provided to help users to test and evaluate the EM3070, which contains beeper & beeper driver circuit, LED & LED driver circuit, trigger & reset buttons, TTL-232 to RS-232 converter & TTL-232 to USB converter, RS-232 & USB interfaces, etc. The EM3070 can be connected to the EVK via a 12-pin flat flexible cable. Either USB connection or RS-232 connection can be used when connecting the EVK to the host.

QuickSet / uExpress

A bunch of software such as QuickSet and uExpress is provided to assist users in application development and function settings for the EM3070 under Windows.



Headquarters / 总部

福建新大陆自动识别技术有限公司

地址: 福建省福州市马尾区儒江西路 1 号新大陆科技园

邮编: 350015

电话: +86 - (0) 591-83979222

传真: +86 - (0) 591-83979208

E-mail: marketing@nlscan.com

WEB: www.nlscan.com

Newland Europe BV/ 欧洲新大陆有限公司

Rolweg 25, 4104 AV Culemborg, The Netherlands

TEL: +31 (0) 345 87 00 33

FAX: +31 (0) 345 87 00 39

Email: sales@newland-id.com

WEB: www.newland-id.com

Tech Support: tech-support@newland-id.com

Newland North America Inc. / 北美新大陆有限公司

Address: 46559 Fremont Blvd., Fremont, CA 94538, USA

TEL: 510 490 3888

Fax: 510 490 3887

Email: info@newlandna.com

WEB: www.newlandna.com

Newland Taiwan Inc. / 台湾新大陆资讯科技股份有限公司

7F-6, No. 268, Liangcheng Rd., Jhonghe Dist. 235, New Taipei City, Taiwan

新北市 235 中和區連城路 268 號 7 樓之 6 (遠東世紀廣場 J 棟)

TEL: +886 2 7731 5388

FAX: +886 2 7731 5389

Email: sales.tw@newland-id.com

WEB: www.newland-id.com.tw